Sage 940RTS Specifications, Continued

Processor Board

Intel Celeron 366 MHz
One Ethernet port
One serial port
SVGA port
PS/2 mouse and keyboard

Operating System

SCO OpenServer UNIX 5.X (5-User License)
Additional user licenses available

Drive Capacity

20 GB

Bus

5 slot standard ISA/PCI
Passive backplane

Alarm/System Management

Form-C Alarm Relay System
Multiple In-Band and Out-of-Band options

Power Supply

-48 VDC
120/240 VAC 50/60 Hz available

Rear Panel Connections

One DB-15 SVGA video
One PS/2 keyboard
One PS/2 mouse
One DB-9 serial port
One RJ45 for T1, 10/100BASE-T, or Token Ring
Four RJ45 for T1
One terminal block alarm

Rack Mounting

Mid-mount for 19" and 23" standard racks
Flush Mount*, Quick disconnect system
One shelf accommodates four Sage 940RTS units

Cooling

Two 17 CFM (0.5 m³/min)
One 43 CFM (1.2 m³/min)
50,000-hour ball bearing ventilation fans allow no more than 10°C rise above ambient temperature

Weight

8.8 lbs. (3.99 kg) with power supply,
fan, backplane, and faceplate

Dimensions

8.75" (H) x 4.35" (W) x 16.91" (D),
17.9" (D) with handle
22.23 cm (H) x 11.01 cm (W) x 42.95 cm (D),
45.47 cm (D) with handle

Compliance

Safety: UL 1950, CSA C22.2 No. 950
IEC 60950/EN 60950

Emissions: FCC Part 15, Class A
EN 55022/CISPR 22 Class A

IEC 61000-3-2 Harmonics

IEC 61000-3-3 Flicker

Immunity: IEC 61000-4-2—ESD

IEC 61000-4-3—Radiated RF

IEC 61000-4-4—EFT

Certifications: UL, C-UL, CE

NEBS: Level 3 compliant

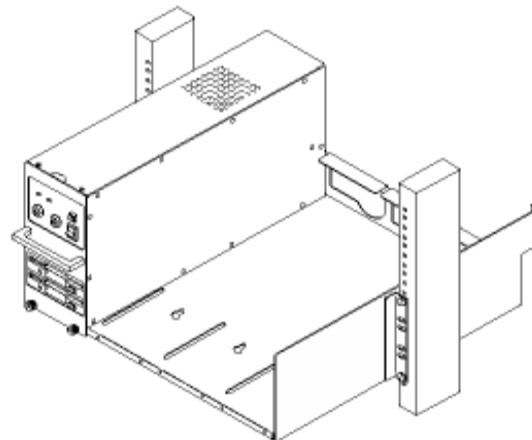

Quick Disconnect Mounting System